

Repair of Utility Cuts Using Interlocking Concrete Pavers

North American cities have thousands of utility cuts made in their streets each year. Figure 1 shows a daily occurrence in most cities: repairs to underground utility lines for water, sewer, gas, electric, steam, phone, fiber-optic, or cable services. A sample is given below of the number of annual utility cuts in a few cities.

Billings, Montana	650-730
Boston, Massachusetts	25-30,000
Chicago, Illinois	120,000
Cincinnati, Ohio	6,000
Oakland, California	5,000
San Francisco, California	10,000
Seattle, Washington	10-20,000
Toronto, Ontario	4,000

The Costs of Utility Cuts

The annual cost of utility cuts to cities is in the millions of dollars. These costs can be placed into three categories. First, there are the initial *pavement cut and repair costs*.



Figure 1. Repairs to utilities are a common sight in cities, incurring costs to cities and taxpayers.

These include labor, materials, equipment, and overhead for cutting, removing, replacing, and inspecting the pavement, plus repairs to the utility itself. Costs vary depending on the size and location of the cut, the materials used, waste disposal, hauling distances, and local labor rates.

Second, there are *user costs* incurred as a result of the repair. They include traffic delays, detours and denied access to streets

by users, city service and emergency vehicles.

User costs depend on the location of the cut. A repair blocking traffic in a busy center city will impose higher costs and inconvenience from delays than a cut made in a suburban residential street. There are downstream costs to users from utility repairs such as lost productivity due to delays, and damage to vehicles from poor pavement riding quality. While these losses are difficult to quantify, they are very present.

The third cost is subtle and long term. It is the *cost of pavement damage* after the repair is made. Cuts damage the pavement. Damage can range from negligible to substantial, depending on the quality of the reinstated area and the condition of the surrounding pavement. The damage reduces pavement life and shortens the time to the next rehabilitation. The need to rehabilitate damaged pavements earlier rather than when normally required has costs associated with it.

Several studies have demonstrated a relationship between utility cuts and pavement damage. For example, streets in San Francisco, California, typically last 26 years prior to resurfacing. A study by the City of San Francisco Department of Public Works demonstrated that asphalt streets with three to nine utility cuts were expected to require resurfacing every 18 years (1). This represented a 30% reduction in service life compared to streets with less than three cuts. Streets with more than nine cuts were expected to be resurfaced every 13 years. This represents a 50% reduction in service compared to streets with less than three cuts.

The report concludes that while San Francisco has some of the highest standards for trench restoration, utility cuts produce damage that extends beyond the immediate trench. "...even the highest restoration standards do not remedy all the damage. Utility cuts cause the soil around the cut to be disturbed, cause the backfilled soil to be compacted to a different degree than the soil around the cut, and produce discontinuities in the soil and wearing surface. Therefore, the reduction in pavement service life

due to utility cuts is an inherent consequence of the trenching process.”

A 1985 study in Burlington, Vermont, demonstrated that pavements with patches from utility cuts required resurfacing more often than streets without patches. Pavement life was shortened by factors ranging between 1.70 and 2.53, or 41% to 60% (2). Research in Santa Monica, California, showed that streets with utility cuts saw an average decrease in life by a factor of 2.75, or 64% (3). A 1994 study by the City of Kansas City, Missouri, notes that “street cuts, no matter how well they are restored, weaken the pavement and shorten the life of the street.” It further stated that permit fee revenue does not compensate the city for the lost value resulting from street cuts (4). A 1995 study by the city of Cincinnati, Ohio, showed that damage to the pavement extends up to three feet (1 m) from the edge of properly restored cuts (5).

The cost of pavement damage includes street resurfacing and rehabilitation to remedy damage from cuts. Permit fees charged by cities to those making cuts often do not fully account for pavement damage after the cut pavement is replaced. Some cities, however, are mitigating the long-term costs of pavement cuts by increasing fees or by charging a damage fee. They seek compensation for future resurfacing costs to remedy pavement damage.

Annual cost of pavement damage from utility cuts to one category of streets (local, collector thoroughfare, etc.)

= Annual cost of resurfacing streets damaged by utility cuts

$$\left[\text{Annual cost of resurfacing streets damaged by utility cuts} \times \left(\frac{\text{Number of years of life remaining before resurfacing streets with utility cuts}}{\text{Expected years of life before resurfacing if there are no utility cuts}} \right) \right]$$

Where the:

Annual cost of resurfacing streets damaged by utility cuts

$$= \left(\frac{\text{percent of all resurfaced streets that are damaged by cuts}}{\text{Total annual cost of resurfacing all streets}} \right) \times$$

$$\left[\text{Total annual cost of resurfacing all streets} \times \left(\frac{\text{Total miles (km) of streets resurfaced that year of one category (local, collector thoroughfare, etc.)}}{\text{total miles (km) of all streets resurfaced in that year}} \right) \right]$$

A damage fee would be derived by dividing the annual cost of resurfacing a particular category of street damaged by utility cuts by the number of years of life expected from those streets. The fee would be higher if a street to be cut had been recently resurfaced, and lower for a street that is about ready for resurfacing.

Table 1—Annual cost of pavement damage from utility cuts (4).

The rationale for fees to compensate for early resurfacing can be based on the following formula in Table 1.

Pavement damage fees may be necessary for conventional, monolithic pavements (asphalt and cast-in-place concrete) because they rely on the continuity of these materials for structural performance and durability. *Cuts reduce performance because the continuity of the pavement surface, base, and subgrade has been broken.* Traffic, weather, de-icing salts, and discontinuities in the surface, in the compacted base, and in the soil, shorten the life of the repaired cut. When pavement life is shortened, rehabilitative overlays are needed sooner than normal, thereby incurring maintenance costs sooner than normal.

Reducing Costs with Interlocking Concrete Pavements

Interlocking concrete pavements can reduce pavement cut and repair costs, and user costs. They can also reduce costs from long term pavement damage, and the fees to rehabilitate them.

Reducing Pavement Cut and Repair Costs— Costs to open interlocking concrete pavements can be competitive with monolithic pavements such as asphalt or poured concrete. Cost savings occur because saw-cutting equipment and pneumatic jack hammers are not required for removal. Since the same paver units are reinstated, additional savings can result from reducing waste and hauling. Minimizing waste material is important in urban street repairs because of compact working conditions and increased landfill costs.

Reducing User Costs—User costs due to traffic interruptions and delays



Figure 2. Removal of concrete pavers for a gas line repair in Dayton, Ohio.



Figure 3. Compaction of the base



Figure 4. Reinstatement of the pavers, bedding and joint sand



Figure 5. The final paver surface is continuous. There are no cuts or damage to the pavement.

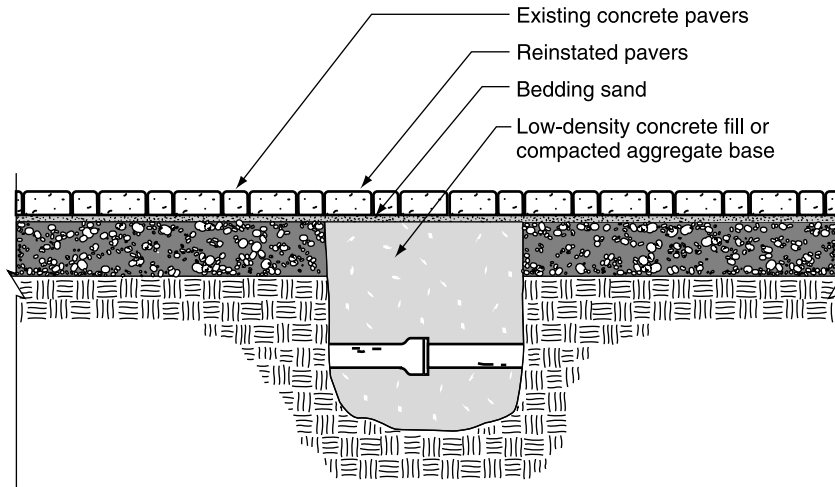

Figure 6. Cross section of reinstated utility cut into interlocking concrete pavement.

are reduced because concrete pavers require no curing. They can handle traffic immediately after reinstatement, reducing user delays. Furthermore, reinstated concrete pavers preserve the aesthetics of the street or sidewalk surface. There are no patches to detract from the character of the neighborhood, business district, or center city area. With many projects, concrete pavers help define the character of these areas. Character influences property values taxes. Attractive paver streets and walks without ugly patches can positively affect this character.

Reducing Costs of Pavement Damage—Since interlocking concrete pavements are not monolithic, they do not suffer damage from cuts. The modular pavers and joints are superior to the cracks from cuts that typically result in accelerated wear to monolithic pavements. The role of joints in interlocking concrete pavement is the opposite from those in monolithic pavements. **Any** break in monolithic pavement, e.g., joints, cuts or cracks, normally shortens pavement life because the continuity of the material is broken. In contrast, the joints of the modular units in interlocking concrete pavements maintain structural continuity.

Figures 2, 3, 4, 5 and 6 show the process of repair and illustrate the continuity of the paver surface after it is completed. The reinstated units are knitted into existing ones through the interlocking paving pattern and sand filled joints. Besides providing a pavement surface without cuts, the joints distribute loads by shear transfer. The joints allow minor settlement in the pavers caused by discontinuities in the base or soil without cracking.

When pavers are reinstated on a properly compacted base, there is no damage to adjacent, undisturbed units. Unlike asphalt, concrete pavers do not deform, because they are made of high strength concrete. The need for street resurfacing caused by repeated utility cuts is eliminated because concrete pavers are not damaged in the reinstatement process. In addition, the use of low density concrete fill can help reestablish the broken continuity

of the base and subgrade. This reduces the likelihood of settlement and helps eliminate damage to the pavement.

Therefore, long term costs of pavement damage from utility cuts to interlocking concrete pavement can be substantially lower when compared to monolithic pavements. This makes interlocking concrete pavement very cost effective for streets that will experience a number of utility repairs over their life. Furthermore, lower costs from less damage can mean lower fees for cuts when compared to those for cutting into monolithic pavements.

Utility Cut Repairs in Asphalt Pavements Using Interlocking Concrete Pavers

Tech Spec 6, *Reinstatement of Interlocking Concrete Pavements*, published by the Interlocking Concrete Pavement Institute, provides step-by-step guidance for repairs to vehicular and pedestrian pavements made with concrete pavers. A unique, experimental variation of the techniques in this technical bulletin is demonstrated in London, Ontario, where repairs to utility cuts in asphalt are made with interlocking concrete pavers (6). The local gas company normally reinstates cut pavement in the winter with cold patch asphalt after making repairs to gas lines. In the spring, the cold patch is typically removed and hot mix asphalt is placed in the openings.

Figure 7 shows the result of settlement and shrinkage of the cold patch asphalt in a London, Ontario, utility cut. The change in dimensions causes the edge of the cut asphalt to deteriorate, and settlement decreases riding quality.

Concrete pavers on low density concrete fill have been successfully used as a replacement for cold patch asphalt (Figures 8 and 9). They were first used as a temporary repair with the intent of being removed in the spring. However, the pavers performed so well that the City of London left them in place indefinitely. Several repairs were in streets subject to heavy truck traffic, as well as residential streets. Costs were less than using cold



Figure 7. Pavement damage from settlement and shrinkage of cold patch asphalt.



Figure 8. Utility cut repair in a residential area in London, Ontario.

patch asphalt.

All repairs in London with concrete pavers and low-density concrete have produced a smooth surface transition from the asphalt to the pavers. The riding quality and safety has improved to the extent that the transition from one surface to the next can barely be discerned by the driver. The pavers were colored to match the appearance of the asphalt so there would be no substantial differences in appearance. Figure 10 shows such a patch of pavers blending with the surrounding pavement.

The base material, controlled low-density concrete fill (sometimes called unshrinkable fill), is a low-strength concrete poured from a ready-mix truck into the trench opening. The concrete fill eliminates the need to replace the aggregate base. The concrete cures to a sufficient strength that the repair with concrete pavers can be opened to traffic within 24 hours, even in freezing weather.

Repair Guidelines for Using Concrete Pavers for Utility Cuts in Asphalt Pavement

The experimental repairs in London, Ontario, have been in place since 1994 and have performed well. The gas company and City continue to make repairs using this method. The ongoing repairs using this method demonstrate that it has particular application in cold climates as a substitute for cold patch asphalt. The use of low-density concrete fill has resulted in no settlement. The smooth riding pavement has increased the public image of the utility company and the City, and has reduced liability. By eliminating the need to remove cold patch asphalt in the spring,

labor forces can be placed on more urgent work.

The following are guidelines from experience with many utility repairs with concrete pavers and low-density concrete fill in London, Ontario.

Signing such as warnings, arrows, flashers, cones and/or barricades should be placed around the area to be cut, according to local, state, or provincial standards.

Cuts in the asphalt pavement should be done with a saw using straight lines. A pneumatic hammer should not be used to cut the asphalt. The saw cuts must be vertical and made completely through the existing asphalt layer. In order to provide clean corners along the edge of the cut, the asphalt layer should not be fractured, suffer from alligator cracking, or be raveled.

The thickness of the asphalt at the opening should be at least 4 in. (100 mm). The sides of the asphalt provide a restraint for the 3.125 in. (80 mm) thick pavers and approximately 1 in. (25 mm) of bedding sand. The interior of the cut asphalt can be broken with a pneumatic hammer and removed with a front end loader. Pieces along the saw cuts should be removed carefully to prevent damage to the edges.

Excavation of the base and soil must be within the limits of the removed asphalt, and care must be taken to not undermine the adjacent pavement. Trench excavation, bracing, shoring, and/or sheeting should be done in accordance with the local authority. Equipment should be kept from the edges of the opening as loads may crack or break pieces from the cut asphalt edges. Excavated soil and base materials should be removed from the site. The trench should be kept free from standing water.

Unshrinkable fill poured into the trench is shown in Figure 11. The fills flows into undercuts, under the edge of the cut asphalt (providing additional support), and in places where the soil or base has fallen from the sides of the trench. These places are normally impossible to fill and compact with aggregate base or backfill material.

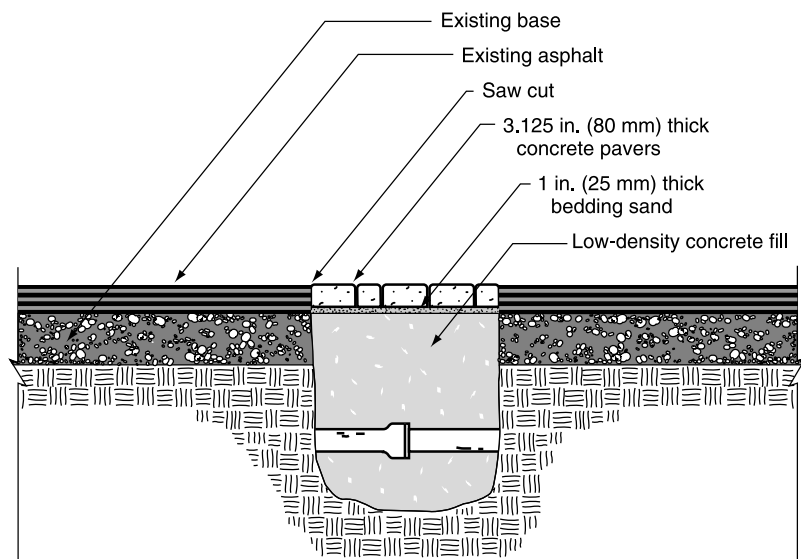

Figure 9. Cross section of utility cut repairs with concrete pavers in London, Ontario

There are many mixes used for low-density concrete fill (7)(8). Proprietary mixtures include those made with fly-ash that harden rapidly. Others are made with cement. A recommended mix can be made with ASTM C 150 (9) Type I Portland cement (or Type 3 for winter repairs), or CAN3-A23.5-M type 10 (or type 30 Portland cement) (10). The slump of the concrete should be between 6 and 8 in. (150 and 200 mm) as specified in ASTM C 143 (11) or CAN3-A23.2.5C (10). When air entrainment is required to increase flowability, the total air content should be between 4 and 6% as measured in ASTM C 73 (11) or CAN3-A23.2-4C (10). Air content greater than 6% is not recommended as it may increase segregation of the mix.

A strength of 10 psi (0.07 Mpa) should be achieved within 24 hours. The maximum 28 day compressive strength should not exceed 50 psi (0.4 Mpa) as measured by ASTM C 39 (11) or CAN3-A23.2-9C (10). Cement content should be no greater than 42 lbs/cy (25 kg/m³). The low maximum cement content and strength enables the material to be excavated in the future. Mixes containing

supplementary cementing materials should be evaluated for excessive strength after 28 days.

Repaired utility lines are typically wrapped in plastic prior to pouring the low density fill. This keeps the concrete from bonding to the lines and enables them to move independently. When the fill is poured, it is self-leveling. It should be poured to within 4 in. (100 mm) of the riding surface of the asphalt.

Bedding sand can be installed when the concrete is firm enough to walk on, generally within a few hours after placement. The bedding sand should be as hard as available and should conform to the grading requirements of ASTM C 33 (11) or CSA A23.1 (10). *Mason sand, limestone screenings or stone dust should not be used.* The sand should be moist, but not saturated or frozen. Screed the bedding with 1 in. (25 mm) diameter screed pipe. Remove excess sand from the opening.

Since the low-density concrete fill is self-leveling, it will create a flat surface for the bedding sand. In most cases, there will be a slope on the surface of the street. Adjustments to the thickness of the bedding sand may be necessary for the finished elevation of the pavers to follow the slope on the surface of the street. This can be accomplished by adjusting the height of the screed pipes.

Concrete pavers should be at least 3.125 in. (80 mm) thick and meet the standards in ASTM C 936 (12) or CSA A231.2 (13). They should be delivered in strapped bundles and placed around the opening in locations that don't interfere with excavation equipment or ready-mix trucks. The bundles should be covered with plastic to prevent water from freezing them together. The bundles need to be placed in locations close to the edge of the opening. Most bundles have several rows or bands of pavers strapped together. These are typically removed with a paver cart. The paver bundles should be oriented so that removal of the bands with carts is done away from the edge of the asphalt.

Rectangular concrete pavers [nominally 4 in. by 8 in. (100 mm x 200 mm)] should be placed against the cut asphalt sides as a border course. They should be placed in a sailor course, i.e., the long side against the asphalt. No cut paver should be smaller than one third of a unit.

Place pavers between the border course in a 90 degree herringbone pattern (Figure 12). Joints between pavers should not exceed 1/16 in. (2 mm). Compact the pavers with a minimum 5,000 lbf (22 kN) plate compactor. Make at least two passes with the plate compactor. A small test area of pavers may need to be compacted to check the amount of settlement. The bedding sand thickness should be adjusted in thickness to yield pavers no higher than 1/8 in. (3 mm) above the edge of the asphalt.

Spread, sweep and compact sand into the joints. The joint sand is typically finer than the bedding sand, and should conform to the grading requirements of ASTM C 144 (11) or CSA A179 (10). The joints must be completely full of sand after compaction. Remove excess sand and other debris. The pavers may be painted with the same



Figure 10. A patch of barely discernable pavers in a heavily trafficked intersection in London, Ontario



Figure 11. Low density concrete fill (unshrinkable fill) poured into a utility trench from a ready-mix concrete truck.



Figure 12. Pavers are laid in a 90 degree herringbone pattern between the border courses.



Figure 13. Concrete pavers in utility cuts can be painted as any other pavement.

lane, traffic, or crosswalk markings as any other concrete pavements (Figure 13).

References

1. Tarakji, G., "The Effect of Utility Cuts on the Service Life of Pavements in San Francisco, Volume I: Study Procedure and Findings," Department of Public Works, City and County of San Francisco, California, May 1995.
2. Shahin, M.Y., Crovetti, J. A. and Franco, J. L., "Effects of Utility Cut Patching on Pavement Performance and Rehabilitation Costs," report prepared by ERES International for the City of Burlington, Vermont in 1985 and published with revisions for the 1986 Annual Meeting of the Transportation Research Board, December 23, 1985.
3. *Comprehensive Study to Evaluate Repair Patches for Asphalt Paved Streets*, a report prepared for Southern California Gas Company by ARE Engineering Consultants Inc., Scotts Valley, California, December 1989, p. 7.
4. *Performance Audit—Public Works Department Utility Cuts Program*, City Auditor's Office, City of Kansas City, Missouri, March 1994.
5. Bodocsi, A. et al., *Impact of Utility Cuts on Performance of Street Pavements*, The Cincinnati Infrastructure Research Institute, Department of Civil & Environmental Engineering, University of Cincinnati, Ohio, 1995.
6. Union Gas Limited, "Unshrinkable Backfill Study," Union Gas London Division, London, Ontario, 1994 with revisions in 1995.
7. "Unshrinkable Fill for Utility Trenches and Streets," Canadian Portland Cement Association, Publication No. CP004.01P, Ottawa, Ontario, 1989.
8. Emery, J. And Johnston T., "Unshrinkable Fill for Utility Cut Restorations," Transportation Research Board Annual Meeting, paper SP93-10, Washington, D.C., 1993.
9. *ASTM Annual Book of Standards*, Volume 4.01, American Society for Testing and Materials, West Conshohocken, Pennsylvania, 1994.
10. *Concrete Materials and Methods of Concrete Construction - Methods of Test for Concrete*, Canadian Standards Association, Rexdale, Ontario, 2000.
11. *ASTM Annual Book of Standards*, Volume 4.02, American Society for Testing and Materials, West Conshohocken, Pennsylvania, 1994.
12. *ASTM Annual Book of Standards*, Volume 4.05, American Society for Testing and Materials, West Conshohocken, Pennsylvania, 1995.
13. Canadian Standards Association, *Precast Concrete Pavers*, CSA-A231.2, Canadian Standards Association, Rexdale, Ontario, 1995.



ICPI
INTERLOCKING CONCRETE
PAVEMENT INSTITUTE

Interlocking Concrete Pavement Institute
13921 Park Center Road, Suite 270
Herndon, VA 20171

In Canada:
P.O. Box 1150
Uxbridge, ON L9P 1N4
Canada

Tel: (703) 657-6900
Fax: (703) 657-6901
E-mail: ICPI@icpi.org
Web: www.icpi.org

WARNING: The content of ICPI Tech Spec Technical Bulletins is intended for use only as a guideline. It is NOT intended for use or reliance upon as an industry standard, certification or as a specification. ICPI makes no promises, representations or warranties of any kind, expressed or implied, as to the content of the Tech Spec Technical Bulletins and disclaims any liability for damages resulting from the use of Tech Spec Technical Bulletins. Professional assistance should be sought with respect to the design, specifications and construction of each project.

Sources for additional information on low-density flowable fill include the Cement Association of Canada, 1500-60 Queen Street, Suite 609, Ottawa, Ontario K1P 5Y7, tel: 613-236-9471 and the National Concrete Ready-Mix Association, 900 Spring Street, Silver Spring, Maryland, 20910, tel: 301-587-9419. The American Concrete Institute offers publication 229R-94, "Controlled Low Strength Materials (CLSM)" at P.O. Box 9094, Farmington Hills, Michigan 48333-9094, tel: 810-848-3700.

Figures 8, 9, 10 and 11 are courtesy of Gavigan Contracting, Ltd., London, Ontario.